

FLEXIBLE PACKAGING SOLUTIONS

VFFS AND CARTONING SYSTEMS





TECMAR
3C-130

AT VOI STEI A SPECIALI

IMA COFFEE

www.ima.it

TECMAR
3C-130



AT VOI STEI A SPECIALI

IMA COFFEE

www.ima.it

TECMAR
3C-130

THE IMA COFFEE HUB



World-leading designer and manufacturer of automatic processing and packaging equipment for numerous industries, IMA Group has recently established the Coffee Hub, a cluster of specialist brands, each providing a key slice of the experience and expertise needed to serve the coffee industry from A to Z.

Comprising a handful of expert companies and supported through consolidated, strategic partnerships, IMA can now address any issue facing coffee producers.

FLEXIBLE PACKAGING BAGS



VERTICAL BAGGERS LINE - FORM FILL & SEAL

The 3SS bagger models guarantees a high performance output in the packaging of ground coffee and beans.

The design of the machines is based on an Open Frame architecture that provides easy cleaning and accessibility for maintenance and operational adjustments. The machines are controlled by a PLC and equipped with a user friendly HMI, a motorized film unwinding unit, a pneumatic film tension controller and a motorized film alignment system. The baggers, intermittent or continuous motion, including degassing valve applicator and N2 flushing system, are capable of producing and filling 3 side seal bags from 50 cc up to 5000 cc.

- 3C-130/OF intermittent or continuous motion - up to 150 p/min
- 3C-200/OF intermittent motion - up to 60 p/min
- 3C-360 intermittent motion - up to 15 p/min
- 3C-80 Dual intermittent motion - up to 70 p/min
- 3C-130 Twin intermittent motion - up to 80 p/min
- PRYSMA intermittent motion - up to 50 p/min



Pillow bag



Gusseted Bag



Block bottom



Hanging holes



Flat top



Degassing valve



Quad seal bag



FLEXIBLE PACKAGING STICKS



STICK LINE

Vertical multiline packaging machines to produce tube style pouches to maximize capacity and optimize packaging material consumption. Suitable for liquids, powders and granulated products.

- STICK-200 - up to 70 p/min
- STICK-400 - up to 70 p/min
- TWIN-200 - up to 70 p/min
- TWIN-400 - up to 70 p/min



Centered vertical seal



Pour spout



Easy opening features



Fin seal



CARTONERS FOR FLEXIBLE PACKAGING



AVA - INTERMITTENT MOTION CARTONING MACHINES FOR FLEXIBLE POUCHES

Configurable intermittent motion equipment that collates and stacks flexible pouches introducing them into cartons or display-boxes.

- AVA 100 - up to 70 p/min
- AVA 200 - up to 70 p/min



Single or multi-product
vertical cartoning

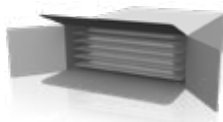

Multi-product
horizontal cartoning

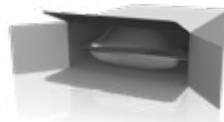

Single product
horizontal cartoning



Display cartoning



EK - CONTINUOUS MOTION CARTONING MACHINES FOR FLEXIBLE POUCHES

Configurable continuous motion equipment that collates and stacks flexible pouches introducing them into cartons or display-boxes.

- EK 100 - up to 150 p/min
- EK 160 - up to 140 p/min

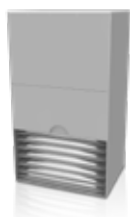

Single or multi-product
vertical cartoning

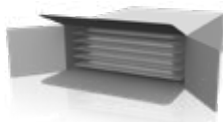

Multi-product
horizontal cartoning

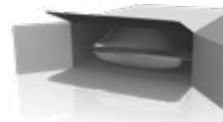

Single product
horizontal cartoning



Display cartoning

TECHNICAL DATA - BAGS

3C-130/OF

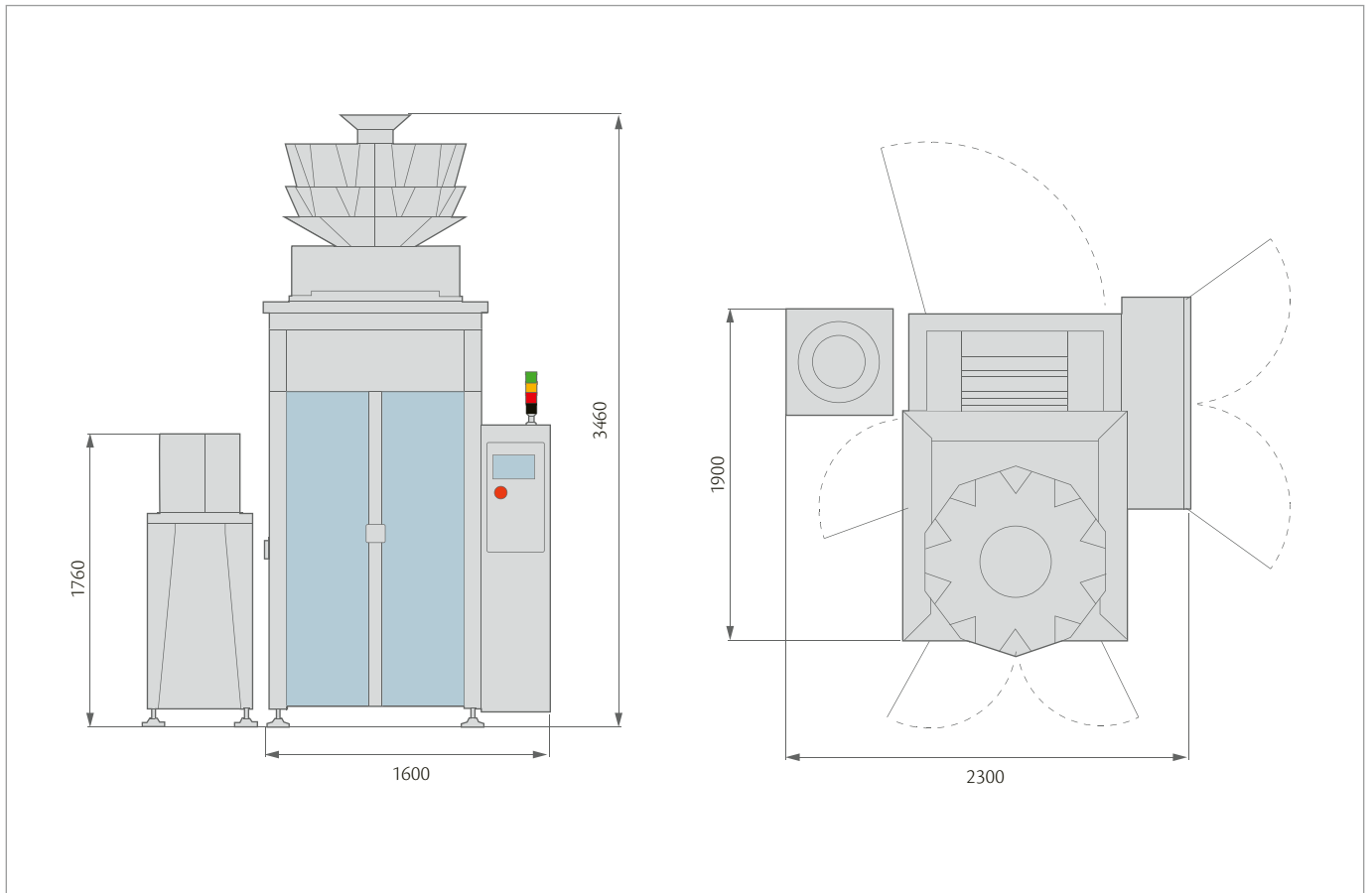

INTERMITTENT MOTION MACHINES

	SEALING WIDTH (min-max / mm)	MAX SPEED - STROKES (p/min.)
3C-130/OF	65-235	80
3C-200/OF	135-350	60
3C-360	350-565	15
3C-80 Dual	65-125	70
3C-130 Twin	65-235	80
PRYSMA	65-220	50

CONTINUOUS MOTION MACHINES

	SEALING WIDTH (min-max / mm)	SPEED - STROKES (p/min.)
3C-130/OF	65-205	150

TECHNICAL DATA - STICKS

STICK-200

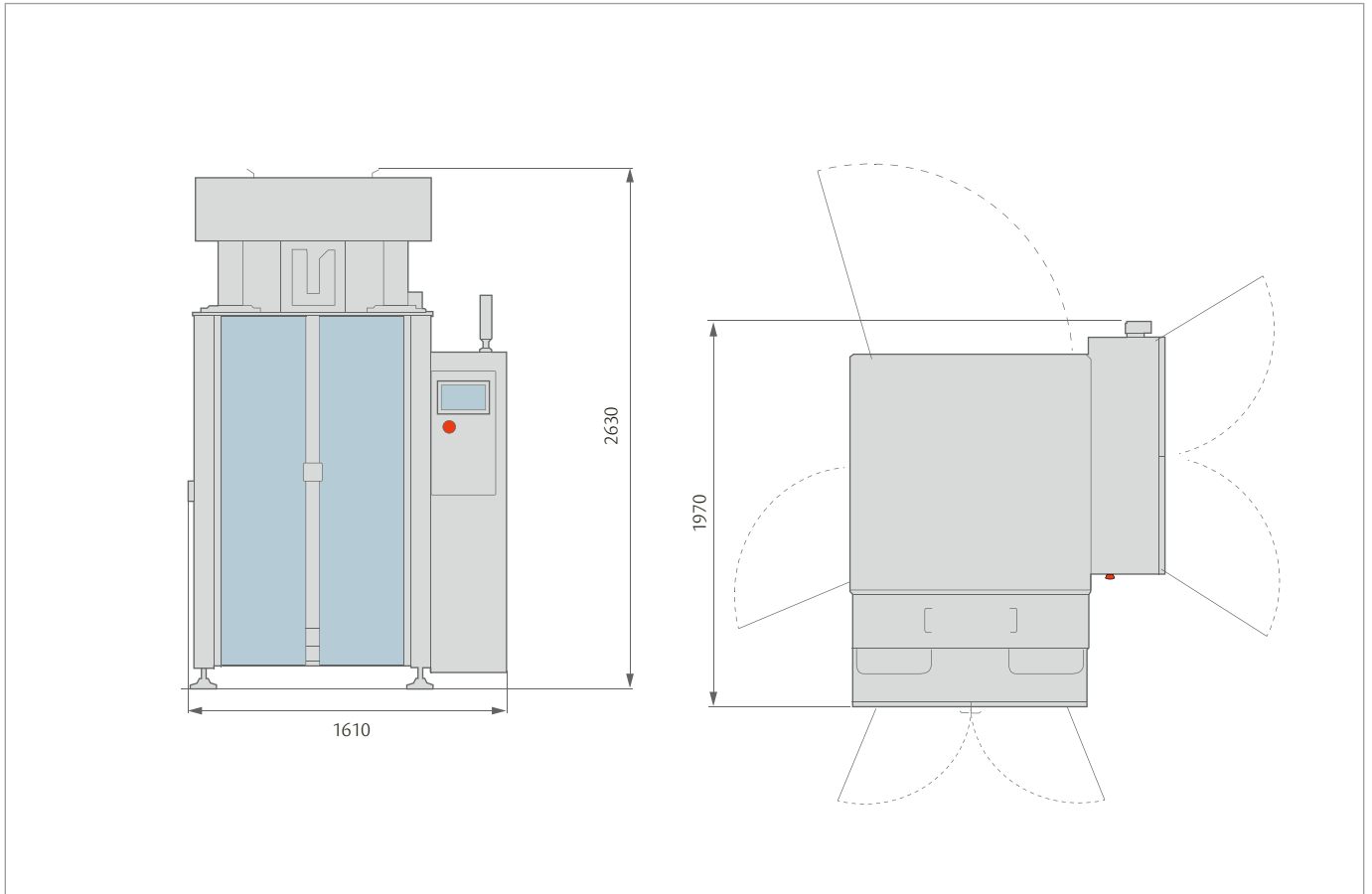

STICK

	SEALING WIDTH (min-max / mm)	MAX SPEED (p/min.)	LANES
STICK-200	15-400	70	12
STICK-400	15-600	70	16

FIN SEAL

	SEALING WIDTH (min-max / mm)	MAX SPEED (p/min.)	LANES
TWIN-200	25-440	70	8
TWIN-400	25-600	70	12

TECHNICAL DATA - CARTONERS

AVA-100

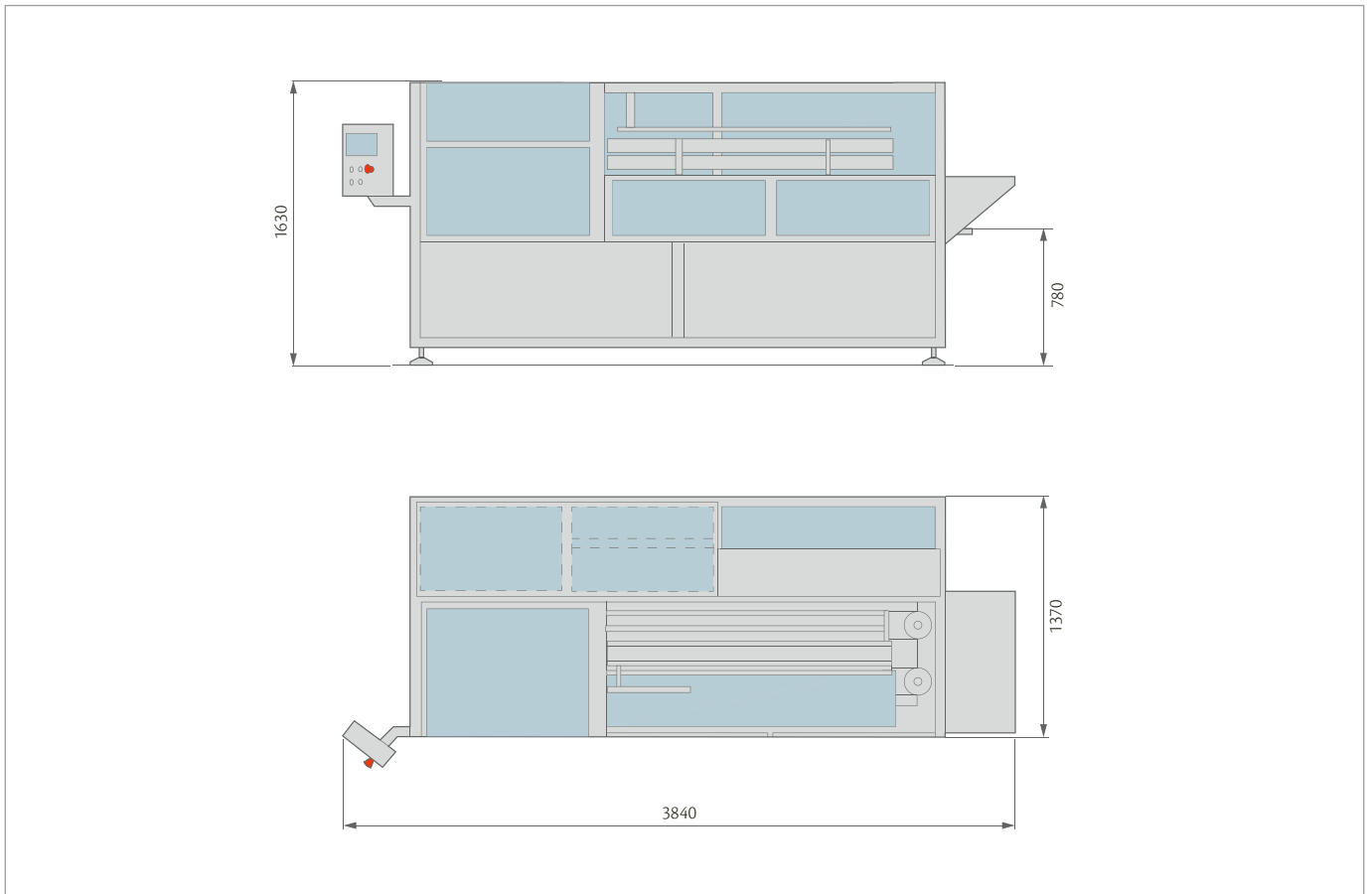

INTERMITTENT MOTION MACHINES (CONFIGURABLE)

	WIDTH (min-max / mm)	LENGHT (min-max / mm)	HEIGHT (min-max /	MAX SPEED (p/min.)
AVA-100	60-110	90-130	30-120	70
AVA-200	100-210	90-150	70-160	70

EK-100

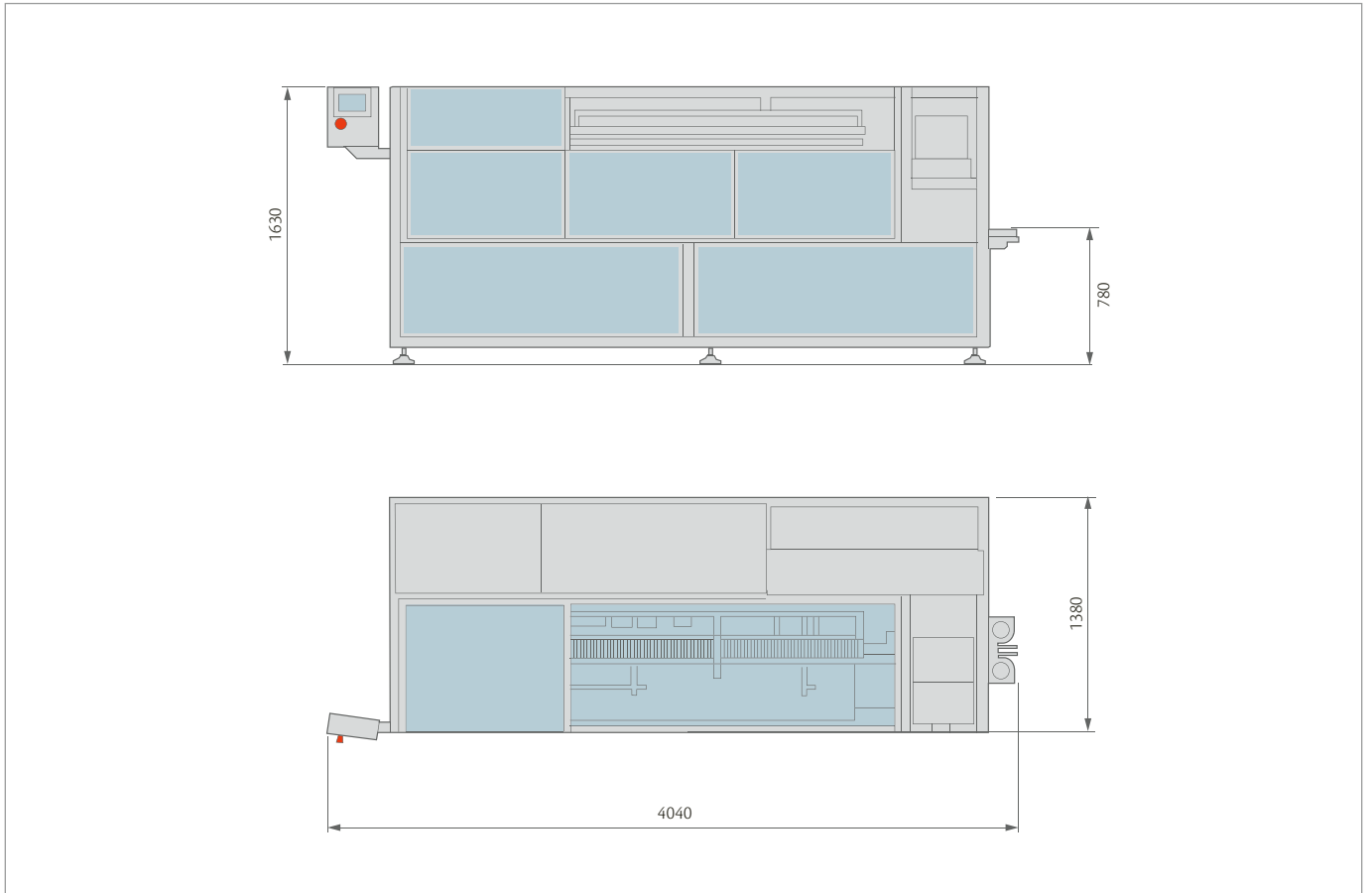

CONTINUOUS MOTION MACHINES

	WIDTH (min-max / mm)	LENGTH (min-max / mm)	HEIGHT (min-max / mm)	MAX SPEED (p/min.)
EK-100	48-100	90-130	25-60	150
EK-160	85-160	95-230	27-110	140

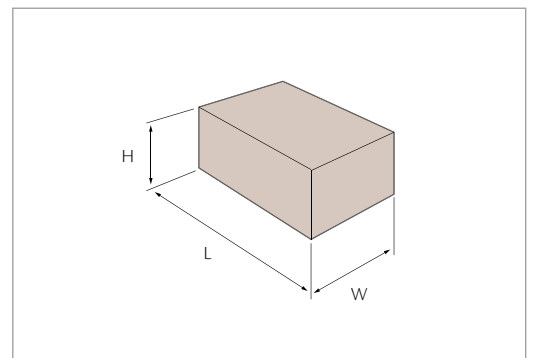

ima.it



TECMAR S.A.

Matteotti 64 - B7608BJB Mar del Plata (Buenos Aires) - Argentina
Tel. +54 481 2020/0008 - Fax +54 223 482 7015
ventas@tecmarsa.com - servicios@tecmarsa.com
www.tecmarsa.com